

Belt Grinding Machine

ANMA type BA



More than 30 years of experience is represented in the range of ANMA belt grinding machines. The BA-range is specially designed as a general purpose grinding machine and includes a powerful motor, quick replacement of belt and easy belt adjustment.



The ANMA machines are prepared for connection to dust extraction systems or can be supplied with a dust exhaust unit built into the pedestal.

The solid construction and the exact wheel balancing results in very low vibration and noise level.

For the sake of safety, the machines have fully enclosed grinding belts and automatic belt tensioning.

Standard Equipment:

- Swing-arm mounting for adjustment of working position.
- Adjustable tool rest at the contact wheel.
- Contact wheel with serrated tyre.
- Pipe for connection to central exhaust system.
- Grinding belt.
- Belt speed 30 m/s.

Extra Equipment:

- Dust exhaust unit.
- Contact wheels with alternative tyres.
- Belt speed 15 m/s or 15130 m/s.
- Other voltages.
- Overload protection.
- No-volt protection.

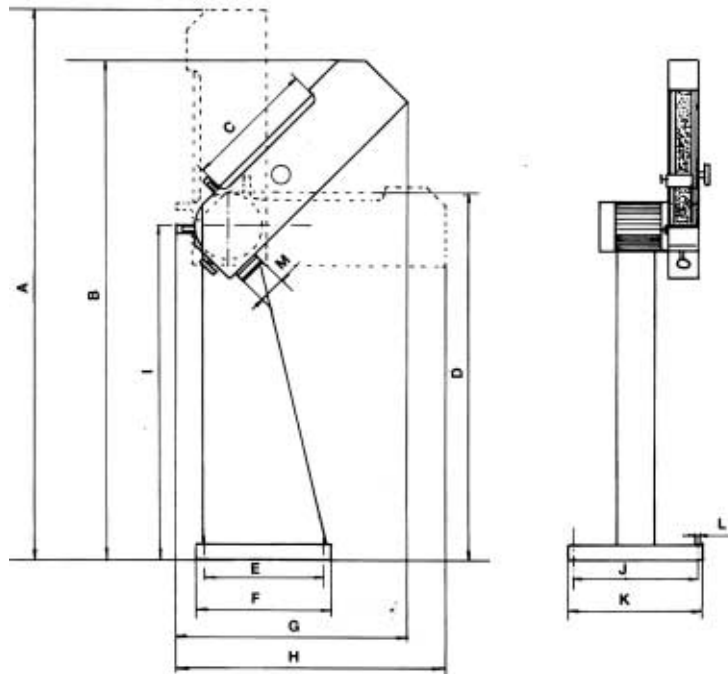

Dimensions (mm):

Type	A	B	C	D	E	F	G	H	I	I	K	L	M
BA 16-50	1590	1460	380	1070	340	390	680	760	970	340	390	Ø11	Ø75
BA 20-50	1790	1600	590	1070	340	390	830	960	970	340	390	Ø11	Ø75

Specifications:

Type	Grinding Belt dimensions mm	Belt speed m/sek	Contact wheel dimensions mm	Motoroutput kW/HK	Motor speed r.p.m.	Voltage standard V	Weight kg	Weight w. exhaust unit kg
BA16-50	50x 1600/1500	30	50xØ200	1,1 / 1,5 0,75 / 1	3000	3x380 1 x220	41	60
BA 20-50	50 x 2000	30	50xØ200	1,1 / 1,5 0.7511	3000	3x380 1 x220	47	66

We reserve the right to change specifications.



ANMA MASKINFABRIK A/S

Tindbjergvej 4
 DK-8600 Silkeborg
 Tel. +45 86 83 69 22
 Fax. +45 86 83 67 88
 www.anma.dk
 info@anma.dk